



*Twenty-Second Annual Undergraduate
Seismic Design Competition (SDC)*



DESIGN GUIDE

Organized and Run by:

EERI Student Leadership Council (SLC)

Competition Website:

<https://slc.eeri.org/2025-sdc/>

Table of Contents

1. OVERVIEW	4
2. Structural Model Materials	4
3. Structural Model Requirements	4
3.1. Structural Floor Plan	4
3.1.a. <i>Floor and Roof Requirements</i>	4
3.1.b. <i>Floor Definition</i>	5
3.1.c. <i>Maximum Floor Plan Dimensions</i>	6
3.1.d. <i>Rentable Floor Area</i>	7
3.1.e. <i>Floor Isolation</i>	7
3.2. Building Zones.....	8
4. Member Requirements	11
4.1. Frame Members	11
4.1.a. <i>Frame Member Violations</i>	11
4.2. Wall Members.....	12
4.2.a. <i>Wall Member Violations</i>	13
5. Connection Requirements	14
5.1. Faying Surfaces.....	14
5.2. Excess Glue.....	15
5.3. Gusset Plates	16
5.4. Base Plate and Roof Plate Connections	16
5.5. Connection Violations	17
6. Floor Requirements	17

7. Floor Dead Load Connections	20
7.1. Floor Dead Load Connection Design Requirements	20
7.2. Floor Dead Load Connection Recommendations	21
8. Base Plate	21
8.1.a. <i>Structural Model Base Plate Lateral Dimensions</i>	21
8.1.b. <i>Structural Model Base Plate Thickness Dimensions</i>	21
8.1.c. <i>Structural Model Base Plate Requirements</i>	22
8.2. Base Plate Notching	23
8.3. Securing the Base Plate to the Shake Table	24
9. Roof Plate Requirements.....	25
9.1. Structural Model Roof Plate Plan Dimensions	25
9.2. Structural Model Roof Plate Thickness Dimensions	26
9.3. Structural Model Roof Plate Requirements	26
10. Innovative Damping Devices.....	26
11. Building Finish	27
12. Structural Model Weight	27
13. Display Requirements.....	27
14. Floor Dead Load Dimensions.....	28
15. Roof Accelerometer	30
16. Instrumentation Schematic	31

1. OVERVIEW

This guide is meant to supplement the *Official Rules* and does not override any of the requirements in the *Official Rules*. The *Official Rules* are not subject to change from the time the *Official Rules* are released to the end of the competition. At the discretion of the Student Leadership Council (SLC), clarifications will be released in response to questions asked. These clarifications will address the relevant ambiguities in line with the spirit of the Official Rules and the Design Guide. As a result, these clarifications override any interpretation of the language in the Official Rules and the Design Guide.

The computer-generated images are examples to illustrate conformity to the rules. Note that many of the images only demonstrate conformity for the specific sections that they directly refer to, and do not necessarily comply with other sections.

This document describes the rules and limitations to be followed for the structural model. Most violations will result in penalties added to V (Official Rules, Section 4.4) some violations may result in disqualification. Penalties will be given in accordance with the Official Rules, Design Guide, and at the discretion of the judges. The SLC reserves the right to cap violations as needed in accordance with the spirit of the competition.

2. STRUCTURAL MODEL MATERIALS

Any violation of this section will result in the structural model not being tested on the shake table and the team being disqualified.

Structural models shall be constructed of only balsa wood. Pre-approved damping devices may be made of any material. Floor labels and the school's name at the top of the building may be constructed out of paper as detailed in Section 13.

Any architectural features (i.e., features not intended for structural purposes) on the model must be made of balsa wood and meet the requirements for a member including all connection requirements.

3. STRUCTURAL MODEL REQUIREMENTS

3.1. Structural Floor Plan

3.1.a. Floor and Roof Requirements

Each violation of this section will result in 5 added to V .

The total number of floors in the structural model, denoted as F , must fall within the specified range of minimum and maximum floors. A floor is defined in detail in Section 3.1.b.

- Maximum number of floors: 19
- Minimum number of floors: 15

A floor, f is required to be within $\frac{1}{4}$ in. tolerance at specific elevations measured from the top of the base plate to the top of the perimeter beams at the floor level.

For instance, the lobby area at $f = 1$ must be precisely at zero inches elevation. For floors ranging from $f = 2$ to the top floor ($f = F$), elevations must adhere to the guidelines outlined in Figures 2 and 3.

A roof is required above the topmost floor ($f = F$) at the height indicated in Figure 2. While the roof does not contribute to the floor count or rentable area, it must adhere to the specifications detailed for a typical floor. Additionally, the roof must have identical floor plan dimensions to the floor directly beneath it (i.e., floor F). Furthermore, the structural model's roof plate must be affixed to the roof structure.

The requirements in this section will be checked with a measuring device along the side of the structural model. **All floor height measurements will be measured from the top of the base plate.**

3.1.b. Floor Definition

Each floor in violation of the requirements in this section will result in 5 added to V .

To be considered a floor, the following requirements must be met:

- A continuous set of perimeter beams shall clearly define the floor where the top of the perimeter beams defines the floor. Walls and non-horizontal frame members may interrupt the continuous set of perimeter beams as long as two horizontal members acting as perimeter beams are at the same elevation and connected to the interrupting member(s). Interior floor beams shall be flush with the top of the perimeter beams. The plane that is defined by the top of the perimeter beams (the floor) shall be flat and level for each individual floor area. Floor 5 and Floor 6 may contain two floor areas, one on either side of the elevated passageway. A continuous perimeter beam shall clearly define each of these floor areas.
- Using a black permanent marker, a dot should be centrally placed on the top of each perimeter beam, so judges know which beams define the floor area for a given floor.

- The lobby floor is defined by straight black permanent marker lines drawn on the base plate between frame or wall members attached to the base plate. A beam at the second-floor level shall be directly parallel to any straight black line drawn on the base plate.
- The continuous set of perimeter beams will be checked visually. The rentable floor area will be checked with a ruler or other measuring device. The floor will be checked for levelness by using a level. If the bubble on the level is completely outside of the level lines, the floor is not considered level. The structural model will be placed on a level floor or table when performing this check.

3.1.c. Maximum Floor Plan Dimensions

Each floor in violation of the requirements in this section will result in 5 added to V .

The maximum floor plan dimensions (inches) are defined in Figure 1 for different building zones along the height of the structural model. All floors of the model must fit within the specified floor plan dimensions. No members may be placed within the hatched areas of these figures. The raised walkway passage requires the “Diagonal for Walkway” in Figure 1 to be within the unbuilt area of minimum 6 inches wide and 7 inches tall.

To check requirements of overall floor plan dimensions a template cutout with maximum floor plan dimensions plus a tolerance of 1/16 inch will be passed over the structural model. The template will remain parallel and not rotated as it passes over the structural model. If the template cannot pass freely over any location, that floor will be in violation. Teams cannot bend or force the template over any floors. To check requirements of the walkway a template of the minimum dimensions minus a tolerance of 1/16 inch will be passed through the walkway. If the template cannot freely pass, then it will be in violation of this section. Additionally, it will be confirmed that a line drawn from one corner of the maximum floor area to its diagonal is within the walkway, as seen in Figure 1.

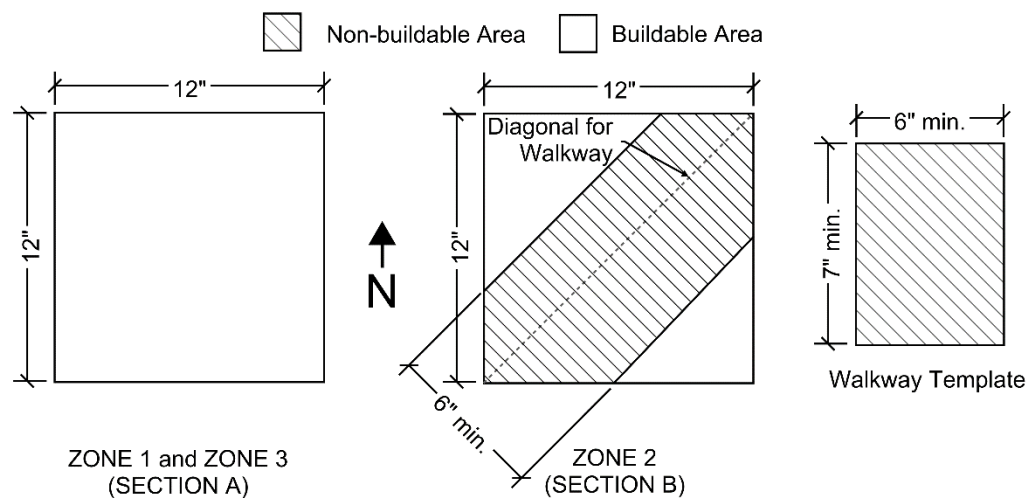

Figure 1 Buildable floor areas for a typical floor in different building zones.

3.1.d. Rentable Floor Area

Any floor area that violates the requirements in this section shall not count towards the rentable floor area. Please see Section 6 of the design guide for detailed requirements on floors.

Rentable floor area may only be within the continuous perimeter beams of the floor (Section 3.1.b).

Each rentable floor area is calculated using the total plan area defined by the perimeter beams, meeting Section 3.1.b and this section's requirements. Individual structural members penetrating the rentable floor area (frame members and wall members) are not subtracted from the rentable floor area.

The maximum rentable total floor area for different building heights is specified in Table 1 (Page 20).

The total rentable floor area will be calculated by summing the individual rentable floor areas from the bottom up. If the maximum rentable total floor area is reached, the remaining rentable floor areas above will not count. Therefore, teams are encouraged to develop unique architectural designs in the top zone without loss of potential building income.

The minimum height clearance for a rentable floor area is 2.25 in.

3.1.e. Floor Isolation

Any violation of this section will result in the structural model not being tested on the shake table and the team disqualified.

Floor isolation of any kind is strictly prohibited. This includes isolating floor dead loads and the roof plate.

3.2. Building Zones

Violating these requirements will result in the structural model not being tested on the shake table and the structure deemed as collapsed for all ground motions.

The structural model of the building is divided into distinct building zones, each characterized by specific features and floor areas. Building zones (and their respective rentable floor areas) are illustrated using different colors in Figure 2. These zones are designed to accommodate rentable spaces while adhering to a unique structural floor plan. Figure 3 details building zones for heights of structures below the maximum number.

- *Building Zone 3* comprises the uppermost floors of the structure, forming the principal area of the structure above the elevated walkway, and is shown in red.
- Located just below *Building Zone 3*, *Building Zone 2* encompasses the subsequent 3 floors. These floors form the main storefronts of the structure at the level of the elevated walkway and is shown in yellow.
- *Building Zone 1* consists of the remaining floors of the structure and is shown in blue. Additionally, *Building Zone 1* includes a lobby at the first floor that boasts a double-height ceiling, creating a grand and welcoming entrance for visitors at this floor.

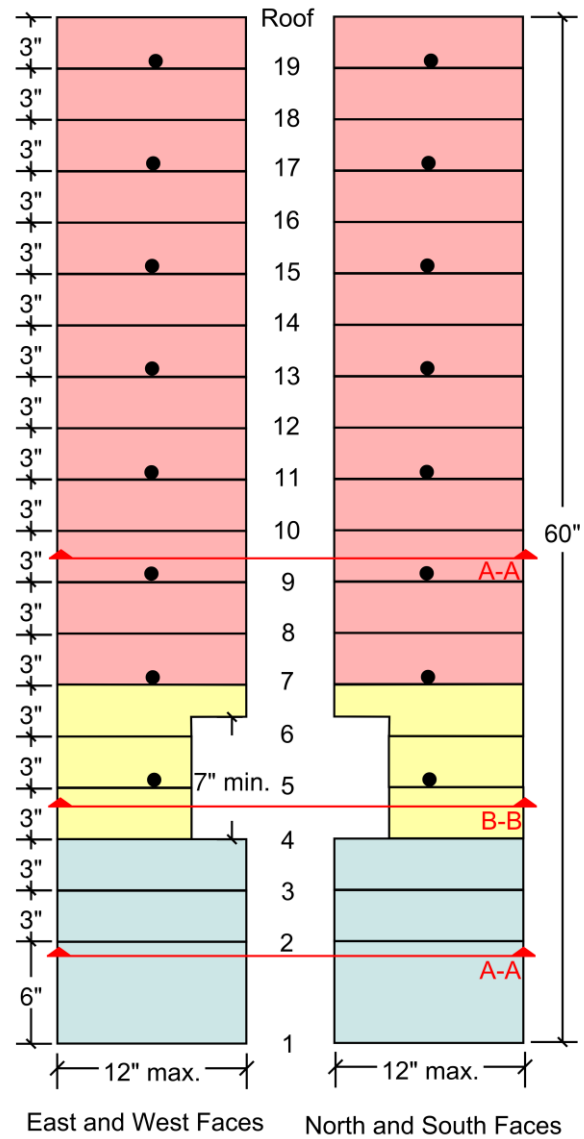

Figure 2 Illustration of building zones in the structural model for $f = 19$. Refer to Figure 1 for notation used in elevation views. Black-filled circles represent the location of dead loads for shake-table testing. Note that building envelope is mirror-symmetrical about its diagonals

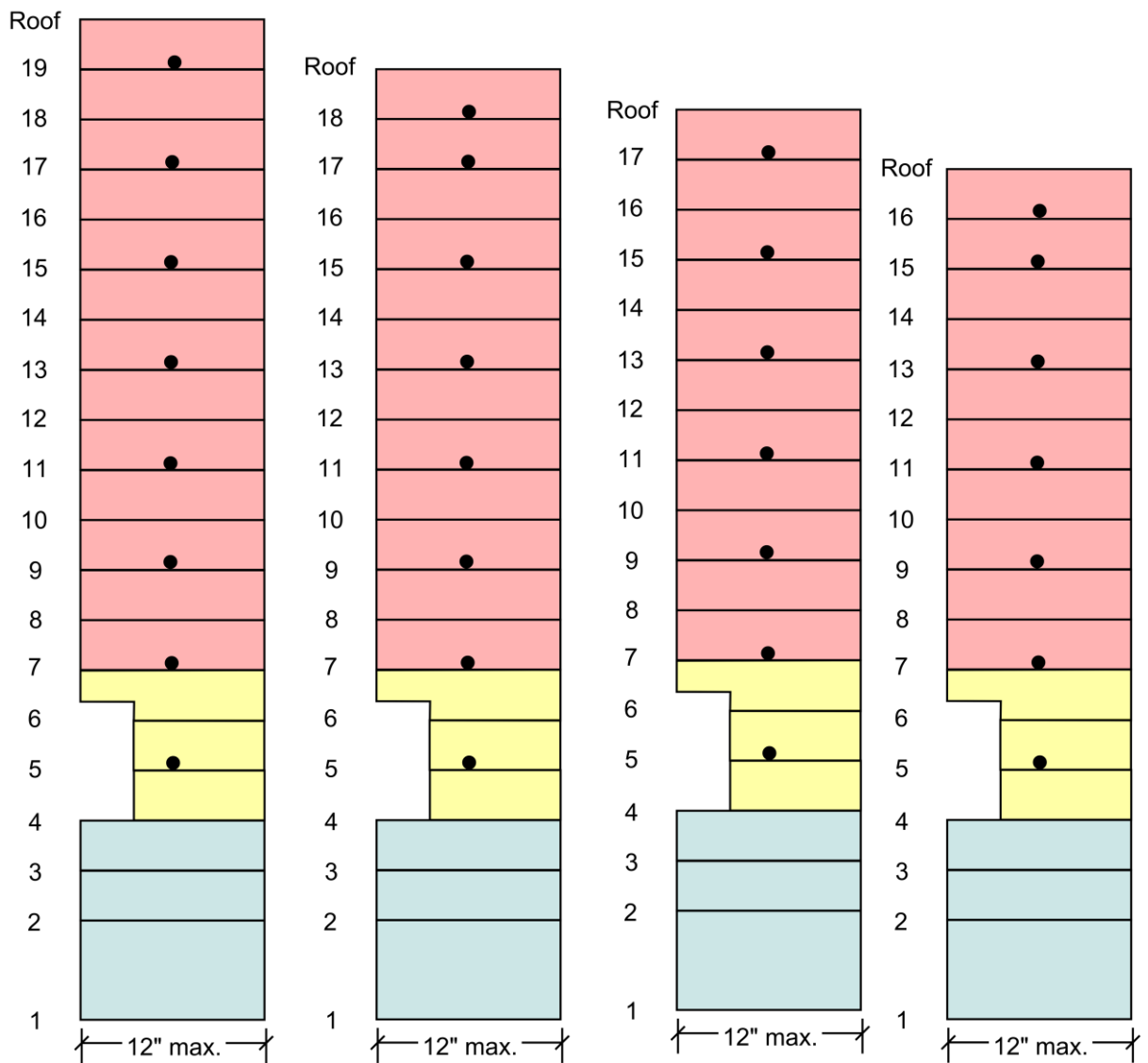

Figure 3 Illustration of building zones in the structural model for $f = 15, 16, 17,$ and 18 . Refer to Figure 1 for notation used in elevation views. Black-filled circles represent the location of dead loads for shake-table testing. Note that only the North/South faces are shown. East/West faces are symmetrical.

4. MEMBER REQUIREMENTS

4.1. Frame Members

Each frame member before any glue is applied and in its final state attached to the model must fit in a box with the dimensions shown in Figure 4 (not to scale). Additionally, the two smallest lengths of an individual frame member must be greater than 0.09 inches in those directions.

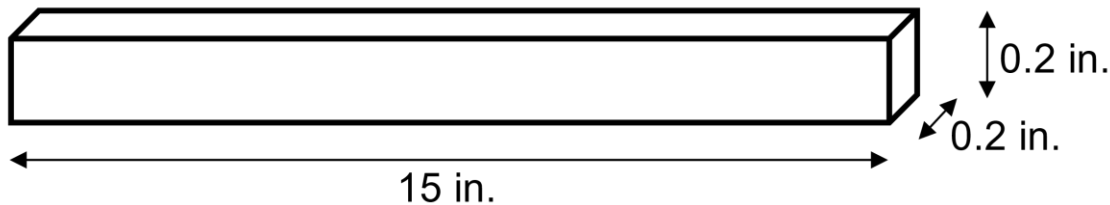

Figure 4 Maximum dimensions for frame members.

This section also applies to curved frame member. The frame member in its final state must fit in a box of the given dimensions.

There are no restrictions on how each member is cut as long as it is able to fit in the box in its final state before any glue is applied. Judges will classify any member that can fit in the frame member box as a frame member. Judges will use discretion when determining the intended type of member, for members that do not fit in either box.

4.1.a. Frame Member Violations

Each member found to be in violation will be assessed a penalty of 2 added to V for every 0.100 in. increment in unit length found to be in violation. Dimensions between increments will be rounded up. A tolerance of 0.01 in. shall apply.

Any two vertical frame members must have a clear space of at least 0.25 in. between them at all points. This requirement does not apply to horizontal or inclined frame members.

Individual frame members will not be removed from the model to check the requirements for this section. Instead, a caliper or other measuring device will be used to check the requirements for this section. Judges must be able to visually observe the extent of all members for measuring. Judges reserve the right to use destructive inspection methods after completion of shaking to assess penalties in this section.

Any frame member to frame member connections not easily visible to the naked eye shall be marked with a black arrow pointing to the connection.

4.2. Wall Members

Each wall member before any glue is applied and in its final state must fit in the box with the dimensions shown in Figure 5 (not to scale).

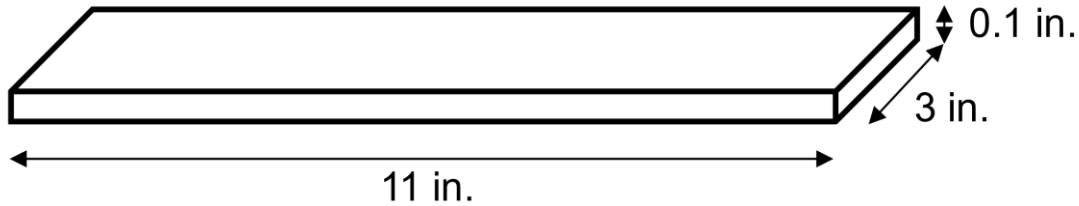

Figure 5 Maximum dimensions for wall members.

Minimum dimensions for wall members include:

- A wall member must span vertically (measured perpendicular to the base plate) at least 2.75 in.
- When measured along the base plate, the width of the wall at any point along its height (not including any closed holes) must be at least 1.0 in. Note: walls with a triangular shape do not meet these requirements.
- Teams should take note that there are restrictions on the orientation of wall members. These minimum requirements are illustrated in Figure 6.

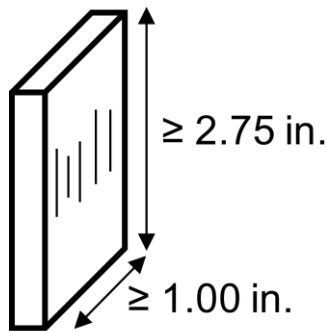

Figure 6 Minimum dimensions for wall members.

4.2.a. Wall Member Violations

Each member found to be in violation of the previous section will be assessed a penalty of 3 V for every 0.100 in. increment in unit length found to be in violation. Dimensions between increments will be rounded up. A tolerance of 0.01 in. shall apply.

Individual wall members will not be removed from the model to check the requirements for this section. Instead, a caliper or other measuring device will be used to check the requirements for this section. Judges must be able to visually observe the extent of all members for measuring. Judges reserve the right to use destructive inspection methods after completion of shaking and assess penalties in this section.

A wall shall be oriented so that the direction of the grain of wood is normal to the top surface of the structural model base plate.

Wall members shall be continuous to the base plate to transfer forces to the ground level.

5. CONNECTION REQUIREMENTS

Individual members in contact shall have glue between the contact surfaces or faying surfaces.

Any members in contact must have glue between the faying surfaces of the two members. It is the discretion of the SDC Chairs to assess V for unglued connections if that connection (regardless of if the two adjoining members are close but are not touching) is reasonably expected to be joined. For example, floor beam elements can be reasonably expected to be connected to perimeter beams and are typically not cantilevered within a footprint of perimeter beams. This requirement is applicable for connections between any types of members (frame, wall, or gusset).

Only glue shall be used between the contact surfaces of individual members. There are no restrictions on the type of glue.

5.1. Faying Surfaces

The faying surface is defined as the surface or portion of a surface of a frame or wall member in direct contact with the surface or portion of a surface of another frame or wall member. Glue shall be between these surfaces. Examples of faying surfaces are shown in Figure 7 below.

For frame members, no single faying surface shall exceed 1 in. in any direction from the centroid of the faying surface.

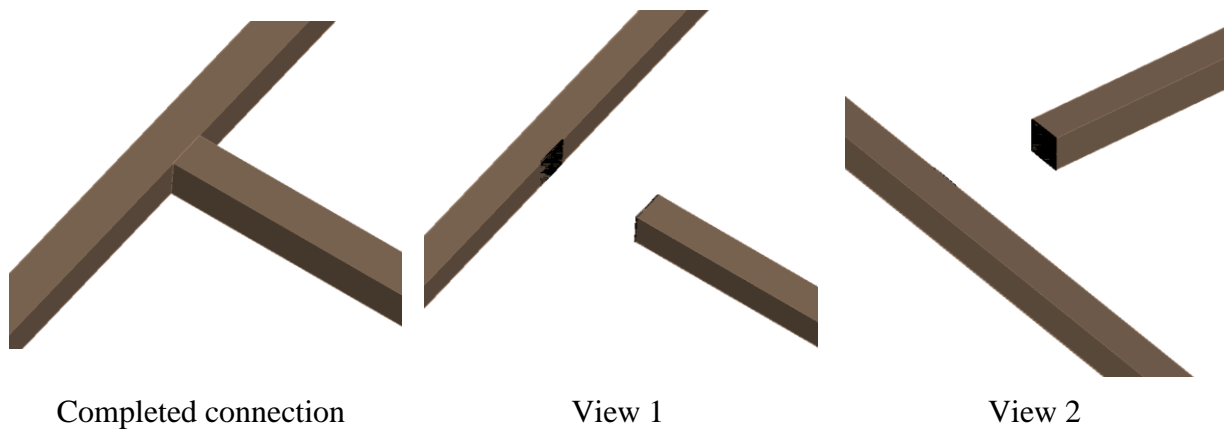

(a) Connection with one faying surface per member.

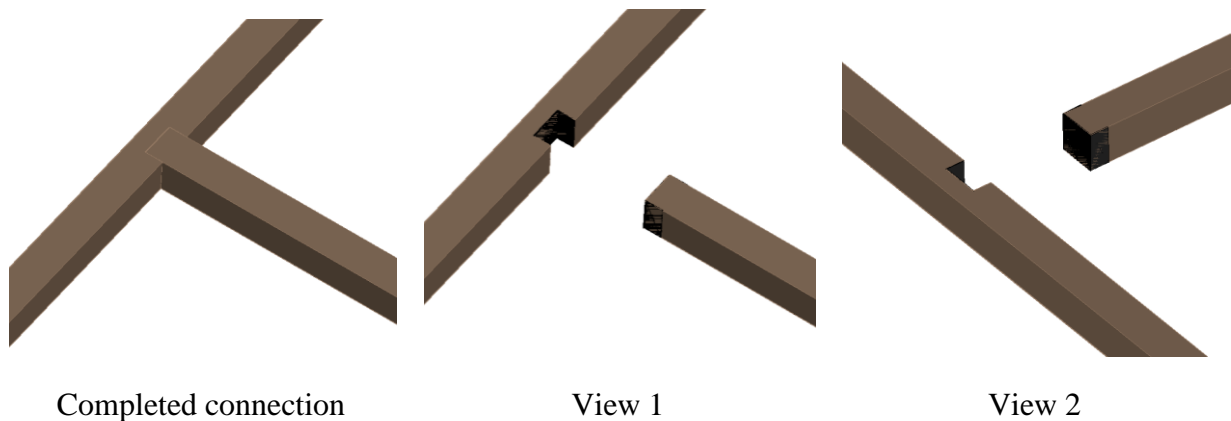

(b) Connection with three faying surfaces per member.

Figure 7 Faying surfaces (shown as shaded areas) for framing members.

5.2. Excess Glue

Excess glue is any glue that is not between the faying surfaces. Excess glue shall not be more than $\frac{1}{2}$ inch in any direction from the edge of a faying surface. Excess glue from each connection shall not be in contact with more than one member. An example of locations where excess glue is permitted is shown below in Figure 8 for $\frac{3}{16}$ in. by $\frac{3}{16}$ in. frame members.

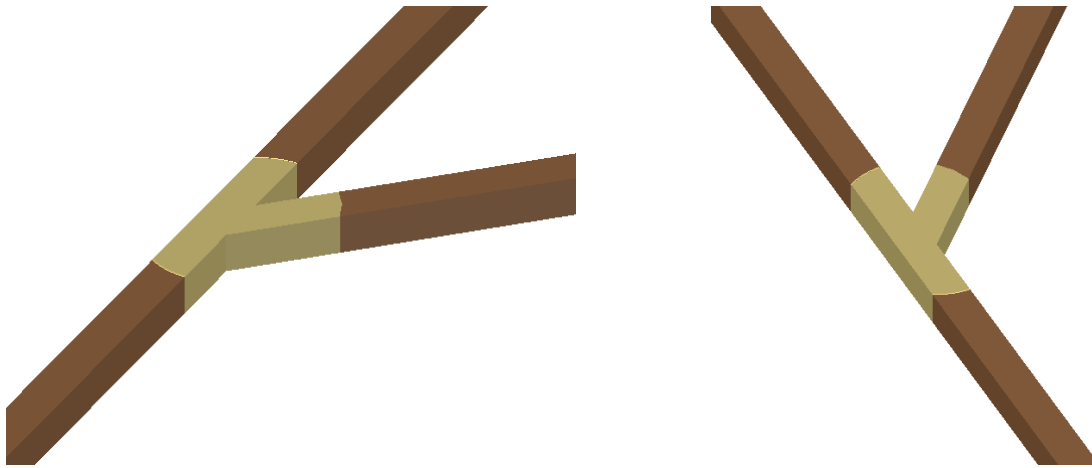

Figure 8 Example of excess glue at faying locations.

5.3. Gusset Plates

Gusset plates are defined as sections that add additional reinforcement at the interface between multiple frame members; they shall not be in contact with any wall members. Each gusset plate shall fit in a box with dimensions 1 in. by 1 in. by 0.10 in. (as shown in Figure 9 below).

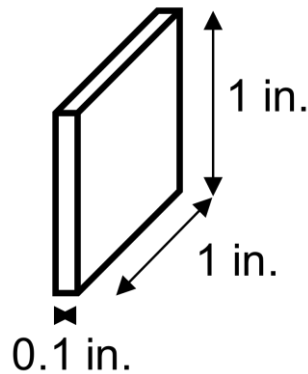

Figure 9 Maximum dimensions of a gusset member.

5.4. Base Plate and Roof Plate Connections

Frame members and/or wall members in contact with the base plate must have glue between the contact surfaces of the member(s) and the base plate. Frame members and/or wall members in contact with the roof plate must have glue between the contact surfaces of the member(s) and the roof plate.

5.5. Connection Violations

Each violation of Section 5 will result in 3 added to V .

6. FLOOR REQUIREMENTS

With the unique design challenge of the 2025 SDC, this section should be carefully considered for total compliance of the structure within the guidelines of this edition of the Design Guide and the *Official Rules*. All units are in inches [in.] unless otherwise noted.

Rentable floor area must be within the perimeter beams and have spans less than 2.5 in. measured perpendicular to any beam. Rentable floor area must have a minimum ceiling height of 2.25 in. and at least one access point to any area at least 1 in. wide and 2.25 in. Minimum ceiling height will be measured from the floor beam and is not permitted to be measured from the ceiling. Each floor area shall have a continuous set of perimeter beams (labeled with a black dot on the top). Any floor plan area shall be confined within the buildable areas as shown in Figure 2. No members may be placed within the hatched areas shown in these figures. Templates shaped and dimensioned like Figure 2 will be passed over the structure without any tilting or rotation to confirm compliance to these limits. The templates will have a tolerance of 1/16 in. in each dimension.

Figure 10 demonstrate various possible maximum measurements for arbitrary shapes. In particular, note that measurements are always taken perpendicular to the frame members surrounding the opening, which applies even for shape with more than 4 sides. The red arrows/lines show the governing measurement; that is, the maximum measurement that can be taken with that floor geometry. All openings must have a governing measurement of no more than 2.5 in. Otherwise, the opening is not considered rentable floor area, and its area will be deduced accordingly from the rentable floor area on that floor. No opening may have more than 4 sides.

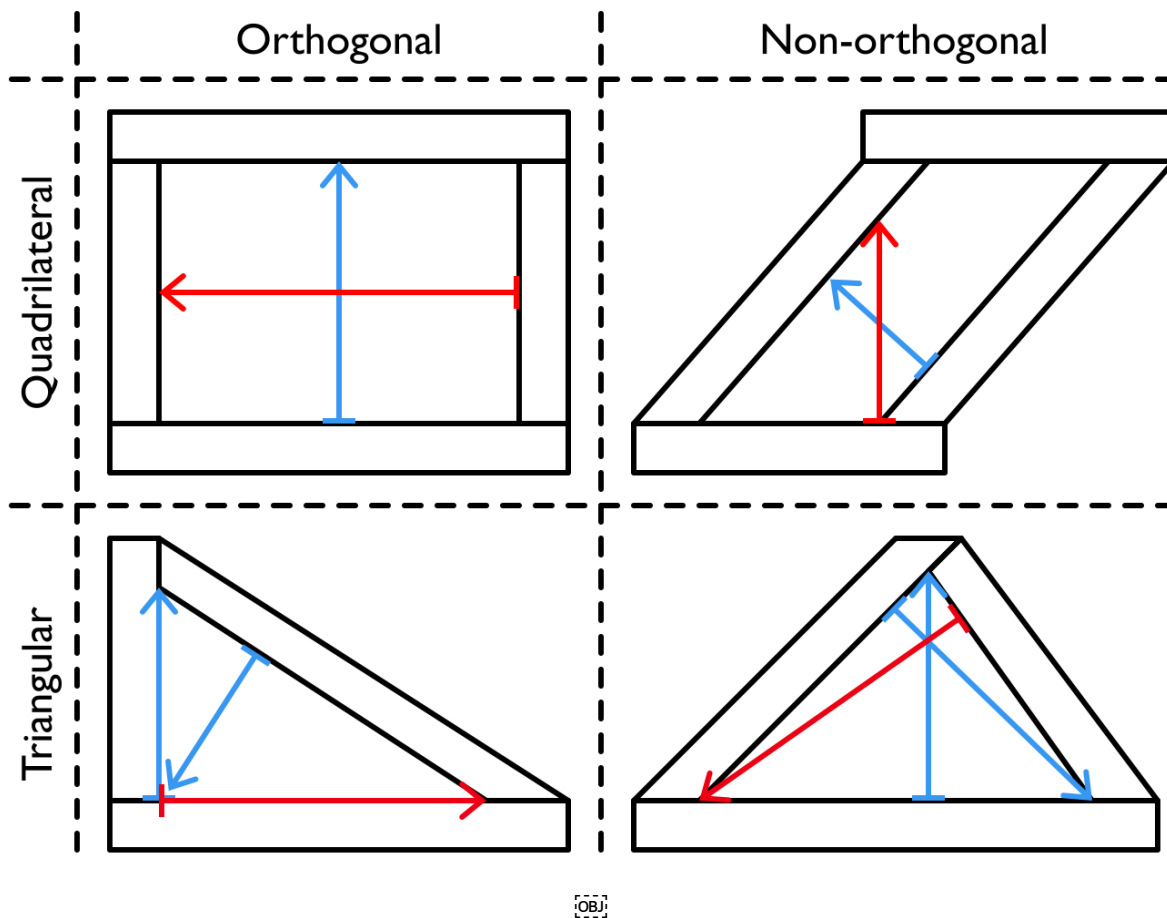

Figure 10 Typical floor plan illustrating member spacing.

The lobby floor is defined by black lines drawn between the frame or wall members attached to the structural model base plate, shown in Figure 11. A beam at the second-floor level shall be directly vertical and parallel to any straight black line drawn on the base plate. Also note the black dots on the perimeter beams in the floors above.

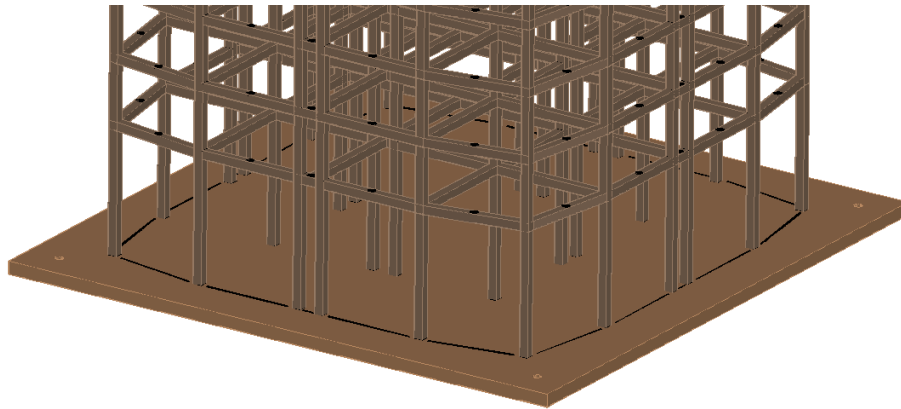

Figure 11 How to draw black lines to define the lobby floor area

Each rentable floor area is calculated using the total plan area defined by the perimeter beams, meeting Section 8.2.b and this section’s requirements. Individual structural members penetrating the rentable floor area (frame members and wall members) are not subtracted from the rentable floor area. Maximum rentable total floor area for different building heights is specified in Table 1. The total rentable floor area will be calculated by summing the individual rentable floor areas from the bottom up. If the maximum rentable total floor area is reached, the remaining rentable floor areas above will not count.

Table 1 Maximum total rentable area.

Number of floors, F	15	16	17	18	19
Maximum possible total floor area [in ²]	1992.4	2136.4	2280.4	2424.4	2568.4
Max. rentable floor area at and below Floor 7 [in ²]	612.5	612.5	612.5	612.5	612.5
Max. rentable floor area above Floor 7 [in ²]	1200.0	1344.0	1488.0	1632.0	1776.0

The minimum height clearance for rentable floor area is 2.25 in, measured from the floor. Occupants on the rentable floor must be able to access any area of the rentable floor through at least one access point or doorway on the floor originating from the interior of the structure. The exterior of the building may not be used as an access point. Additionally, occupants on the lobby floor, or $f = 1$, should be able to access the exterior of the building through at least two access points or doorways. Similarly, at floor $f = 4$ there should be at least one access point into each of the two floor areas. A sufficient access point is defined as a clear opening measured from the top of the floor with the following minimum dimensions:

- Width: 1 in.
- Height: 2.25 in.

7. FLOOR DEAD LOAD CONNECTIONS

Floor dead load connections are required at the floors specified in Figure 2 and Figure 3 in both the East-West (E-W) and North-South (N-S) directions. Due to the unique design of the structure, the floor dead load connections are defined at different locations across floors. Please refer to Figure 2 and Figure 3 for the different potential dead load layouts.

The dead load will be simulated using rods spanning across the E-W and N-S directions. The bottom of the dead load rod shall be in contact with the top of the perimeter beam on the floor where the load is to be applied. After installing the rod, a series of washers and plates will be placed near its ends, and nuts will be used to hand-tighten the plates in place. The washers will sit flush against the exterior face of the perimeter beams. Proper bracing should be included to ensure that no members or connections break during the tightening process. A dead load assembly example is shown in Figure 16.

7.1. Floor Dead Load Connection Design Requirements

Each violation of this section will result in 5 added to V .

All members used in floor dead load connections must conform to the frame or wall member requirements.

Floor dead load connections are required in both North-South and East-West directions and to be placed according to Figure 2.

The floor dead load connection shall be designed so that the bottom of the threaded rod is resting on top of the perimeter floor beams at the following floors:

- For $f = 19$, on floors $f = 7, 9, 11, 13, 15, 17$, and 19 .
- For $f = 18$, on floors $f = 7, 9, 11, 13, 15$, and 18 .
- For $f = 17$, on floors $f = 7, 9, 11, 13, 15$, and 17 .
- For $f = 16$, on floors $f = 7, 9, 11, 13$, and 16 .
- For $f = 15$, on floors $f = 7, 9, 11, 13$, and 15 .

The dead weights should be able to be installed and nuts be tightened to ensure a snug fit without breaking any of the connections, frame members, or wall members in the structural model.

Floor dead loads will be secured to the structure using nuts and washers.

7.2. Floor Dead Load Connection Recommendations

A time limit will be implemented for teams installing floor dead loads. Ensure the connections are not too intricate that they require an excessive amount of time to install.

The connection should be strong enough for the team to tighten the nuts enough to engage adequate friction between the innermost washer and the exterior face of the building to ensure the floor dead load is secure

It is *strongly* recommended that each team purchase a sample weight to try out and ensure proper attachment. Penalties will be assessed for dead weights that are not secured to the structural model after each ground motion testing and may result in judges deeming the building collapsed. Base Plate Requirements

8. BASE PLATE

The base plate shall be made of commercially available plywood (at least 3-ply) or MDF. The bottom of the base plate must be flat and smooth).

8.1.a. Structural Model Base Plate Lateral Dimensions

Any dimensional violation in this section greater than 0.25 in. may result in the judges not allowing the structural model to be tested on the shake table and, therefore, the model will be assumed collapsed for both ground motions.

An 18.00 in. by 18.00 in. square continuous wooden (Plywood or MDF) base plate will be used to attach the model to the shake table. Teams are responsible for providing a wood base plate.

To ensure uniformity and proper alignment, the outer perimeter of the structure at any level should not be closer than 1.25 in from the outside edge of the structural model base plate to allow securing the structural model to the shake table (Figure 12).

All measurements will be checked with a tape measure or other measuring device.

8.1.b. Structural Model Base Plate Thickness Dimensions

Any dimensional violation in this section resulting in the base plate thickness falling outside of the indicated range may result in the judges not allowing the structural model to be tested on the shake table and assuming the model is collapsed for both ground motions.

The wood base plate shall be between 0.25 in. to 0.50 in. thick.

All measurements will be checked with a caliper.

8.1.c. Structural Model Base Plate Requirements

The model will not be tested if the base plate does not meet the requirements in this section. In this case, the model would be considered collapsed for both ground motions.

Notching the base plate is allowed but only at locations where a frame member or wall member is in contact with the base plate. The notched area must be filled in completely with the frame member, wall member, or glue. Glue may not be present 1/4 in. from the edge of any member breaking the plane of the top of the base plate visible from the top of the base plate. Each violation of the requirements for notching the base plate will result in 5 added to V .

Excessive notching is not permitted. The judges will add 100 to V in cases where excessive notching is found.

On the top of the base plate, a letter 'N' or the word 'North' shall be written with black permanent marker within 1 in. from the North edge and within 6 in. of the East edge of the base plate. The 'N' sign needs to conform with the direction specified in Figure 1.

The bottom of the base plate must be flat and smooth. If the judges deem the structural model cannot be firmly affixed to the shake table, the accelerometer will not be attached to the structural model and maximum damage will be assumed for the first ground motion. If the structural model cannot be physically attached to the shake table, the structural model will not be tested, and the structural model will be assumed collapsed for both ground motions. Failure of the base plate (i.e., delamination, crushing or fracture) that causes the structure to become unstable, to rock back and forth unattached from the base, or to fall off the shake table is considered a collapse of the structure.

A second identical wood base plate shall be provided by the team for judges to weigh in lieu of weighing the base plate attached to the structural model. The second identical base plate shall have the name of the school written in black permanent marker. Identical notching is not necessary in the second base plate. If the judges deem the second base plate is not identical or the team fails to provide a second identical plate, the judges will assign the base plate a tare weight of 0.0 lbs. Therefore, the weight of the base plate will be included in the Structural Model Weight W_s (Section 12) used for scoring purposes.

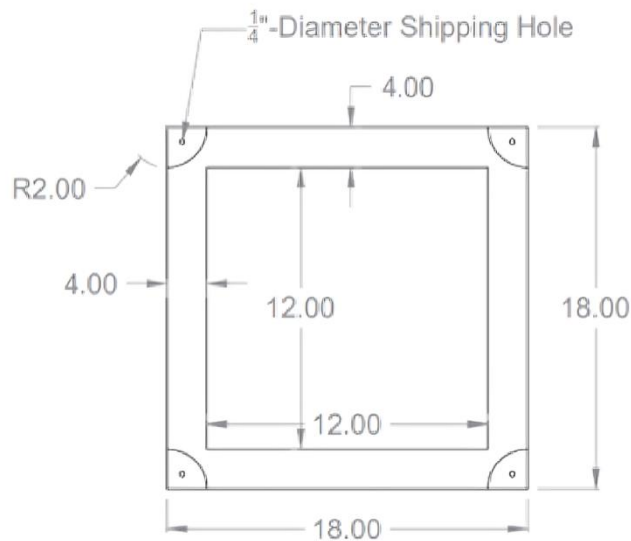

Figure 12 Typical base plate for model.

8.2. Base Plate Notching

Notching the base plate is allowed, but only at locations where a frame member or wall member are in contact with the base plate. The notched area must be filled in completely with the frame member, wall member, or glue. Glue can only be present within 1/4 in. from the edge of a member breaking the plane of the top of the base plate ([Section 5.2](#)).

An example is shown in Figure 13:

- The far-left notch has a 3/16 in. x 3/16 in. frame member and glue filling the 5/16 in. diameter void, which meets the criteria for base plate notching.
- The top-most notch has a 3/16 in. x 3/16 in. frame member and glue filling most of the 3/4 in. diameter void which does not meet the criteria for base plate notching due to insufficient glue in the hole and glue extending 1/4 in. beyond the frame member edge breaking the top plane of the base plate. This will result in 10 added to V for two violations.
- The bottom-most notch has glue filling a notch without a member within 1/4 in. breaking the top plane of the base plate. This will result in 5 added to V .
- The far-right notch has glue mostly filling a notch without a member within 1/4 in. breaking the top plane of the base plate. This will result in 10 added to V for two violations of not filling the void and glue 1/4 in. beyond a member breaking the top plane of the base plate.

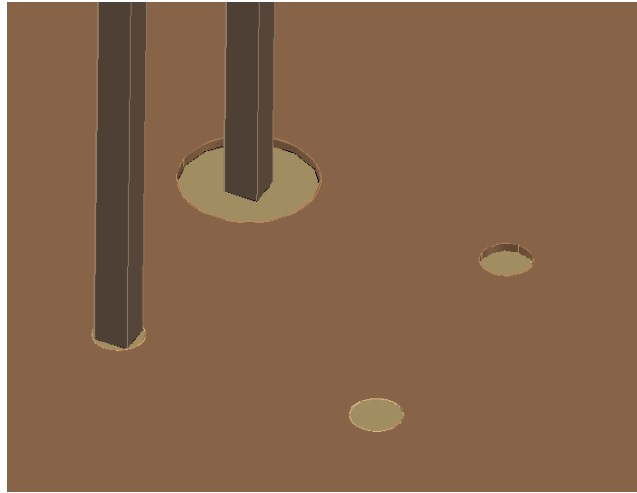

Figure 13 Notching example.

8.3. Securing the Base Plate to the Shake Table

Two 18 in. long steel angles (1 in. legs and 1/8 in. wall thickness) will span on top of the structural model base plate perpendicular to the direction of shaking on each side of the building. The two steel angles will be secured with the 4 corner clamps. Two 12 in. long aluminum angles (1 in. legs and 1/8 in. wall thickness) will span on top of the structural model base plate parallel to the direction of shaking on each side of the building. The two aluminum angles will be secured with a center clamp.

If the base plate is warped, the corners of the base plate will be clamped so there are no gaps at the corners between the shake table base, the steel angle, and the base plate. A Seismic Design Competition Chair will check each clamp after installation. See the diagram below in Figure 14 for where the angles will be located. A clamp will be installed at the locations with a black circle on the diagram.

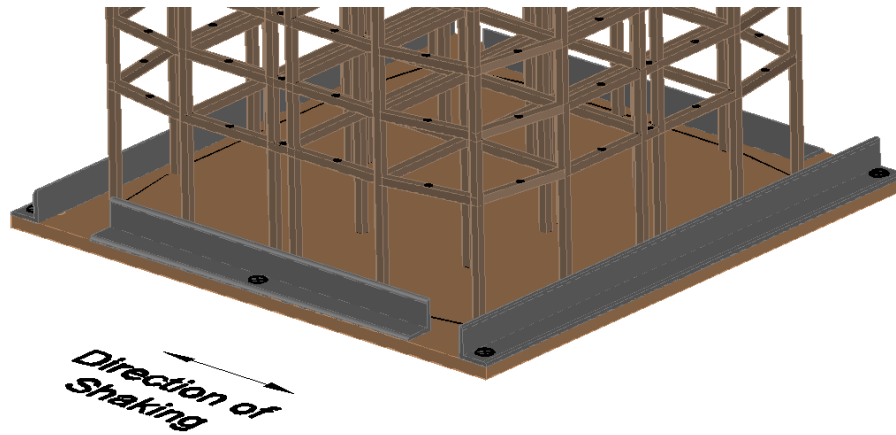

Figure 14 Typical attachment of base plate to the shake table.

9. ROOF PLATE REQUIREMENTS

The roof plate shall be made of commercially available plywood (at least 3-ply) or MDF. Teams are advised to use a 3/8 in. plywood and independently verify that the measured thickness falls within the required range.

The structural model roof plate will be where the accelerometer is attached for shaking. Care must be taken when designing the roof beams to allow for two C-clamps to clamp the accelerometer to two diagonally opposing corners of the structural model roof plate. The structural model roof plate shall be level and centered on the roof so that the centroid of the roof plate coincides vertically with the centroid of the base plate. If the judges deem that the roof plate is not level or centered, or that it is not made of the allowed materials, or that the accelerometer cannot be attached for any other reason, then the accelerometer will not be attached to the model and the team will receive an APS equal to 100%.

9.1. Structural Model Roof Plate Plan Dimensions

Any dimensional violation in this section greater than 0.25 in. may result in the judges not allowing the accelerometer to be attached to the structural model during shaking.

A 6.00 in by 6.00 in square continuous wood roof plate is needed to attach the accelerometer to the building. The roof must contain the entire square roof plate on its surface. No part of the roof plate is allowed to not land on the roof surface.

All plan measurements will be checked with a tape measure or other measuring device.

9.2. Structural Model Roof Plate Thickness Dimensions

Any dimensional violation resulting in the roof plate thickness falling outside of the indicated range will result in 20 added to V and may also result in the judges not allowing the accelerometer to be attached to the structural model during shaking.

The roof plate thickness shall be between 0.3 in. and 0.4 in. Therefore, teams are recommended to use 3/8 in. plywood or MDF plates and independently verify that the measured thickness falls within the indicated range.

All thickness measurements will be checked with a caliper.

9.3. Structural Model Roof Plate Requirements

Due to safety concerns, the roof accelerometer will not be attached if the roof plate does not meet the requirements in Section 9.3.

Notching the roof plate is allowed, but only at locations where a frame member or wall member are in contact with the roof plate. The notched area must be filled in completely with the frame member, wall member, or glue. Glue may not be present 1/4 in. from any edge of a member breaking the plane of the bottom of the roof plate visible from the bottom of the roof plate. Each violation of the requirements for notching the roof plate will result in 5 added to V.

The top of the roof plate must be flat and smooth. If the judges deem the accelerometer is not firmly affixed to the structural model using two C-clamps (scaled drawings of the C-clamps will be provided in the *Design Guide*), the accelerometer will not be attached to the structural model.

A second identical wood roof plate shall be provided by the team for judges to weigh in lieu of weighing the roof plate attached to the structural model. The second identical roof plate shall have the name of the school written in black permanent marker. Identical notching is not necessary in the second roof plate. If the judges deem the second roof plate is not identical or the team fails to provide a second identical plate, the judges will assign the roof plate a tare weight of 0.0 lbs. Therefore, the weight of the roof plate will be included in the Structural Model Weight W_s (Section 12) used for scoring purposes.

10. INNOVATIVE DAMPING DEVICES

All damping devices must be approved in the Damping Device Approval Process (*Official Rules*, Section 7). Any use of a damping device that is not pre-approved or in a pre-approved location will result in disqualification. The implementation of such a device needs to allow for the placement of weights as discussed in Section 7.

11. BUILDING FINISH

Any violation of this section will result in the structural model not being tested on the shake table and the team being disqualified.

The finish on all frame and wall members must be bare wood. Paint or other coatings will **not** be allowed on any portion of the model. Burned surfaces from laser cutting are permitted.

12. STRUCTURAL MODEL WEIGHT

For scoring purposes, the Structural Model Weight, W_s , is equal to the weight of the structural model including damping devices but **does not** include the weight of the floor dead loads, roof dead load, base plate, or roof plate.

Due to the capacity limits on the shake table, the structural model shall not be approved for shake table testing and will be deemed collapsed for all ground motions if the weight of the structural model, damping devices, base plate and roof plate exceed 5.0 lb. If this section is violated, teams will not be allowed to modify their base plates in order to reduce the weight below the 5.0 lb limit.

13. DISPLAY REQUIREMENTS

Four pieces of paper no larger than 1.5 inches by 6 inches each shall be affixed to the building with the name of the university. One paper shall be facing each of the four cardinal directions.

Each floor shall be labeled with a number written on a piece of paper taped to the floor, directly on the balsa wood, or on a small piece of tape touching no more than 1 frame member. The bottom-most floor is not required to be labeled. The floor above the lobby shall be labeled “2”, and so on. The label must not be designed to assist in the structural performance or interfere with the installation of the dead weights.

Failure to meet all requirements in this section by the designated time listed in the schedule will result in 5 added to V. Incorrect floor numbering, if dead load connections are correctly placed, will also result in 5 added to V. Incorrect numbering causing load misplacement will result in the building not being tested at the shake table and deemed as collapsed for all ground motions.

14. FLOOR DEAD LOAD DIMENSIONS

The floor dead load dimensions are shown in Figure 15 and Figure 16.

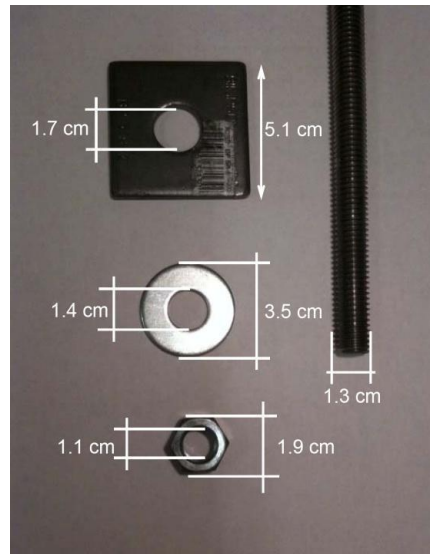

Figure 15 Dimensions of dead-weight components used throughout structure (1 in = 2.54 cm).

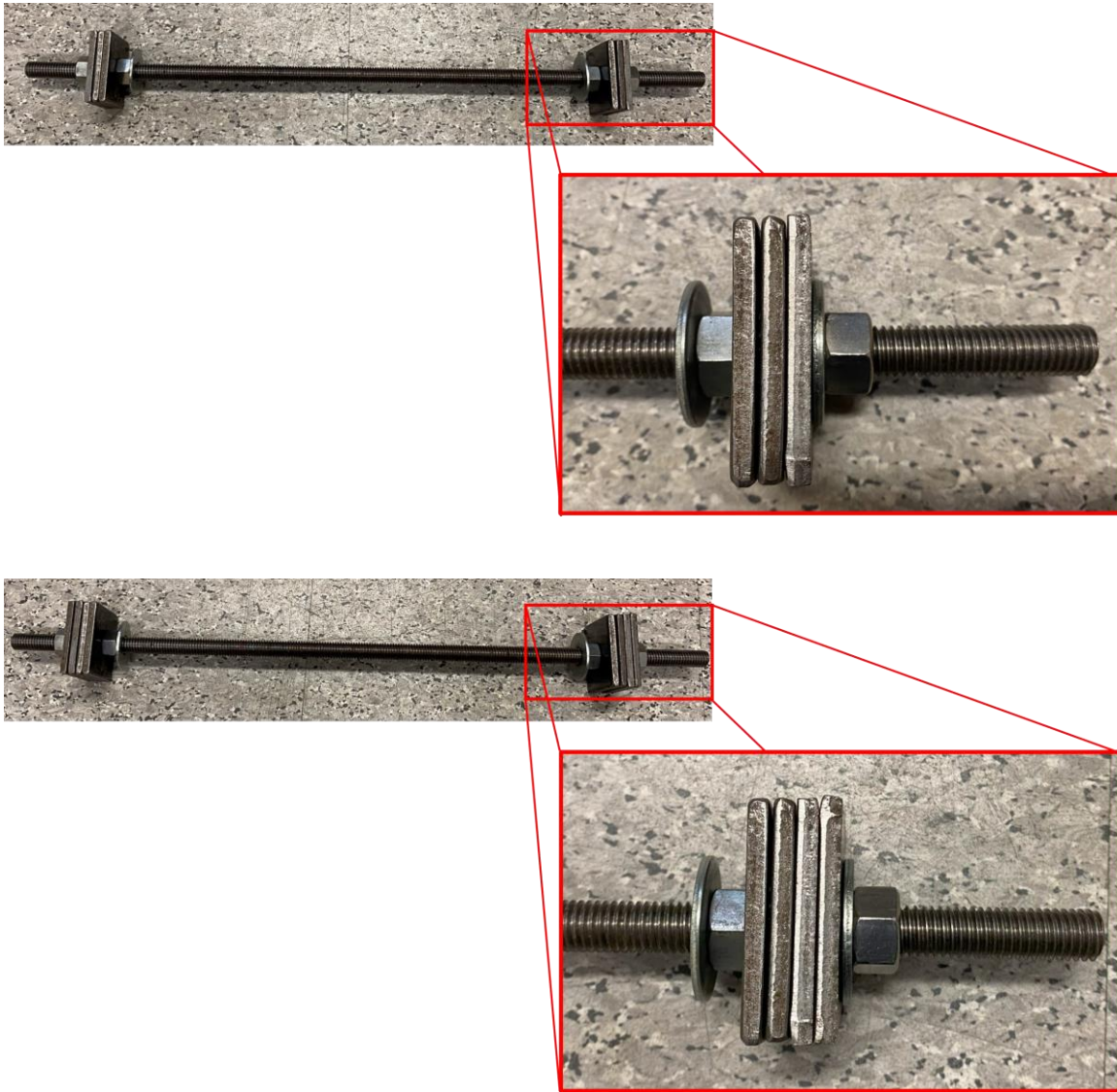
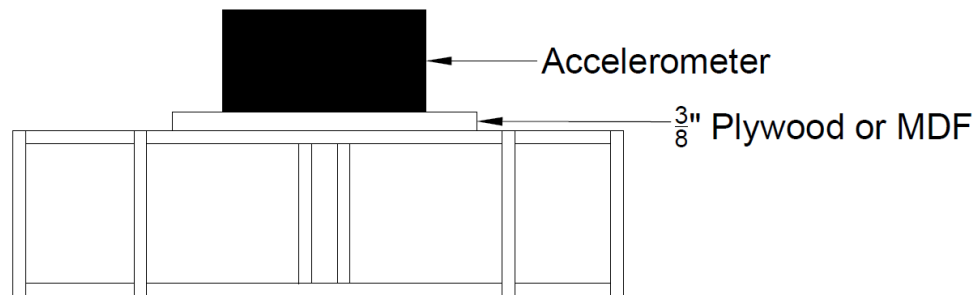

Figure 16 (TOP) Dead weight configuration for a typical floor. (BOTTOM) Dead weight configuration on the highest relevant floor.

15. ROOF ACCELEROMETER

The roof accelerometer schematic is shown in Figure 17 below:

Roof Elevation View



Bracing System Not Shown

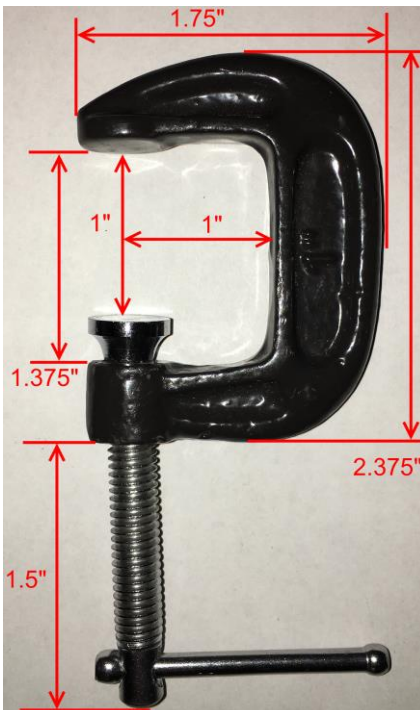

Figure 17 Location of roof accelerometer and dimensions of c-clamps used to secure roof accelerometer (1" = 2.54 cm).

16. INSTRUMENTATION SCHEMATIC

The instrumentation setup is illustrated in Figure 18 below:

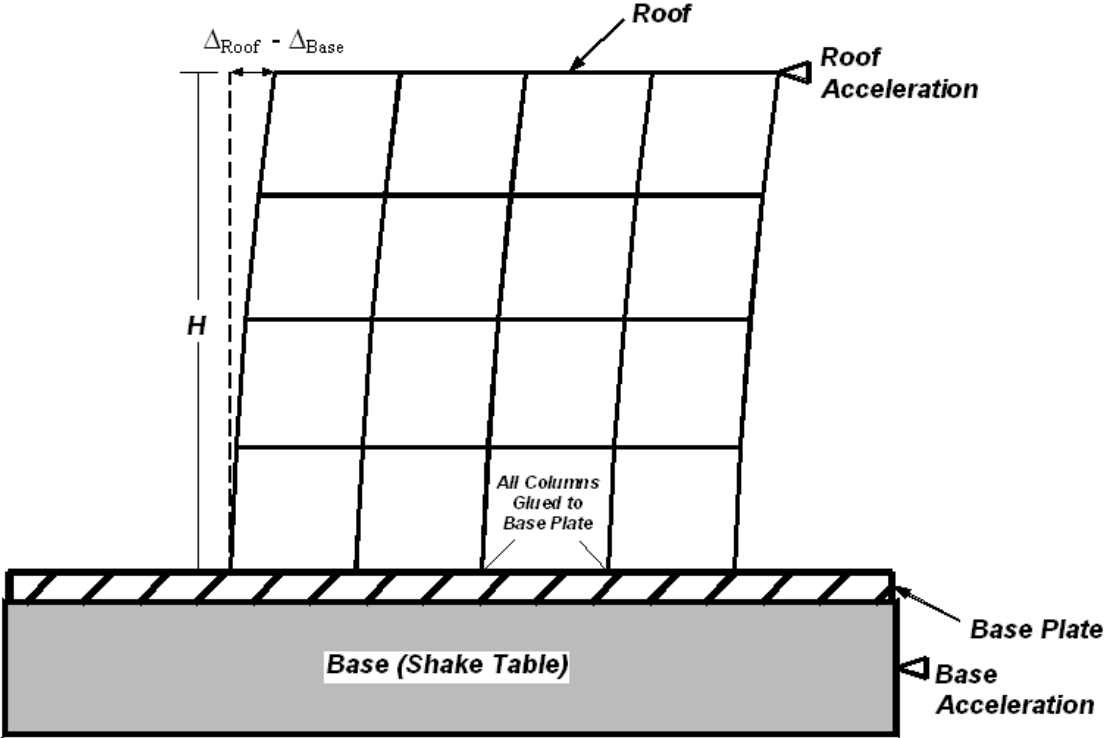

Figure 18 Typical set-up of model shakedown.